

Manual

TM5512

TM5511

Auto transfer controller

TH312116ER1

The Interpretation of the symbol



WARNING:

A WARNING indicates a potentially hazardous situation which, if not avoided, could result in death, or equipment damage.



NOTE:

Provide the user's help is very useful information and tips or alert the operator to the correct operation.

History

No.	Rev.	Date	Editor	Validation	Changes
1	TH312116ER1	2017.4	L	C	NEW



WARNING:

Read this entire manual pertaining to the work to be performed before installing, operating, or servicing this controller. Practice all plant and safety instructions and precautions. Failure to follow instructions can cause personal injury and/or property damage.



WARNING:

Controllers contain static-sensitive parts. Observe the following precautions to prevent damage to these parts.

During installation, care must be taken to prevent static electricity.



CAUTION:

The controller comes with the factory settings. As the factory settings may not fully meet the actual user needs, the GENERator settings must be checked before.

Contents

1、 Description	1
2、 The Outline Dimension Drawings and Controller Wiring	2
3、 Panel Operation	6
4、 Control and Operation Instruction	8
5、 Measure and display data	17
6、 Parameter settings:	18
7、 Installation Guide.....	40
8、 LCD displays and Menu System.....	41
9、 Technical Specification	44

1、 Description

TM5512/TM5511 is an automatic transfer switch controller that is suitable for automatic switching control of two power supplies. It integrates electrical parameter measurement display, automatic switching control, status monitoring display and three remote functions. Through the settings, the controller can realize automatic conversion of two power supplies with different types of transfer switches. The combination of two power supplies can be mains electricity and mains electricity, mains and power generation, or power generation and power generation.

Features:

- I True RMS measure of voltage and current
- I 132*64 dot matrix LCD display
- I Multi-Language menu
- I 4 configurable control relay outputs
- I 4 configurable D-inputs
- I Calendar and clock
- I Clocked event recording and measurement parameter recording
- I To achieve the scheduled time to start and shut down
- I Panel buttons to set the mode of operation
- I System maintenance time presetting and reminding function
- I LED visually shows the operating state of the transfer switch and the controller operating mode
- I Select function of auto change and auto recovery or auto change but doesn't auto recovery
- I Conversion restrictions
- I Support multiple communication systems
- I Through LCD panel display and buttons to set operating parameters
- I USB port and PC connection, can read and modify all settings and data
- I Optional RS485 communication port for remote monitoring (only for TM5512)

2. The Outline Dimension Drawings and Controller Wiring

2.1 Details:

Module Dimensions	W156mm×H120mm
Panel Cutout	W123mm×H96mm
Thickness	D39.5mm

TM5512

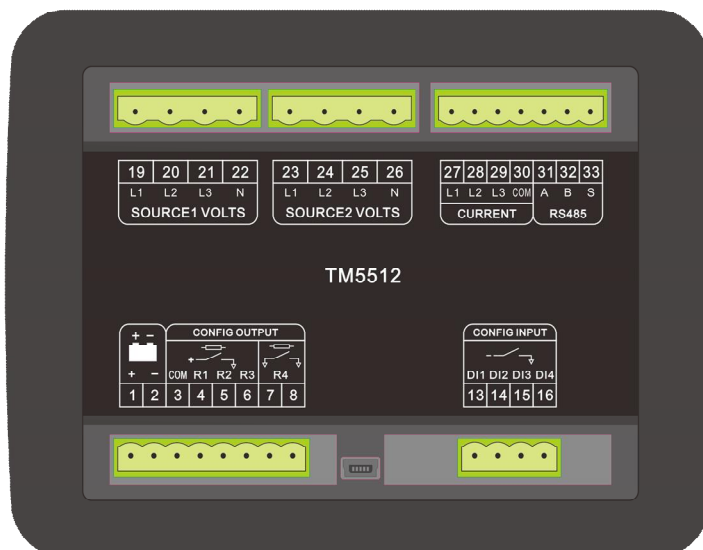
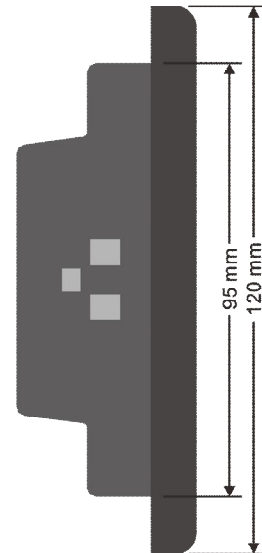
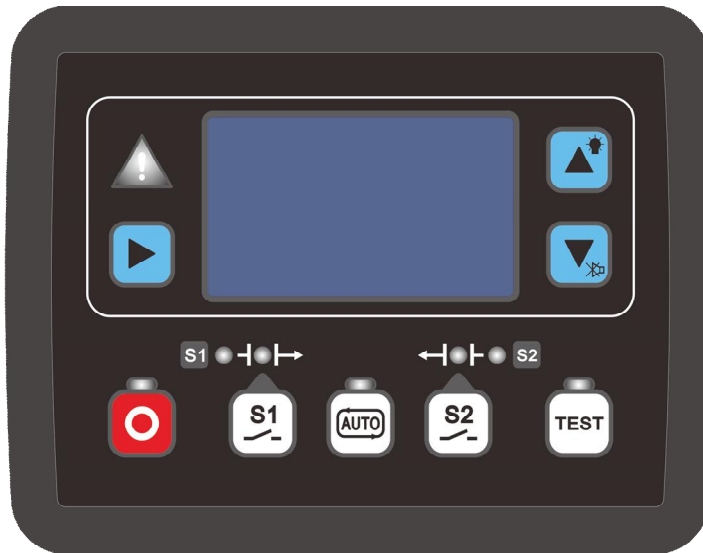
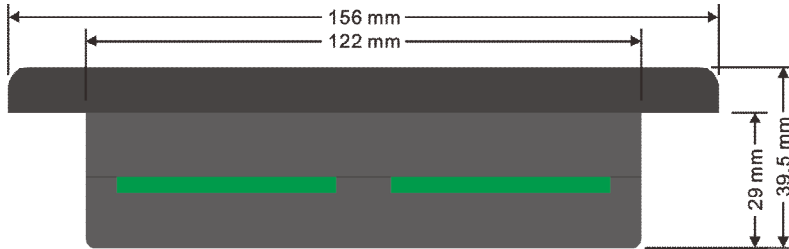

TM5511

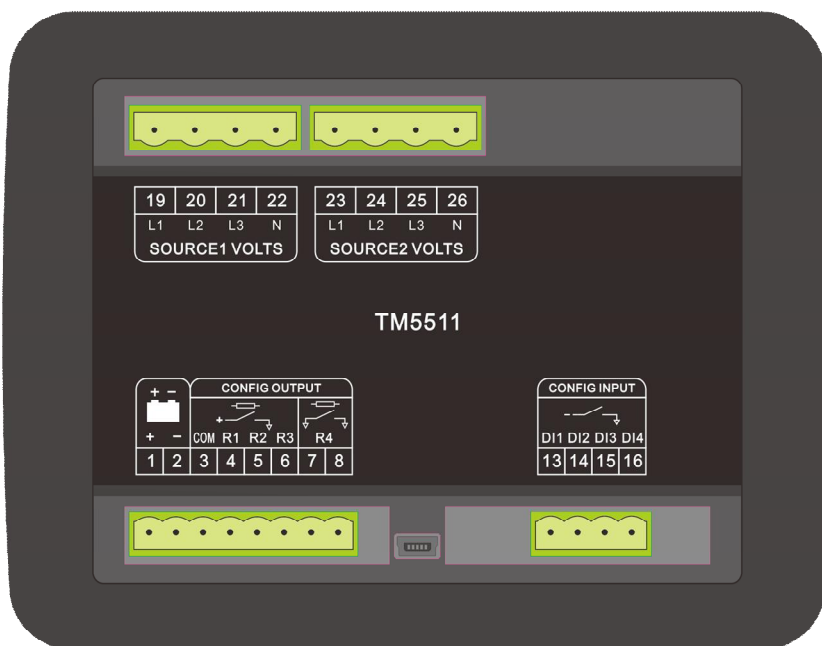
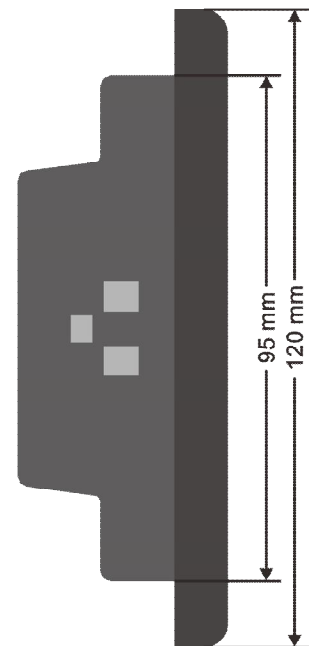
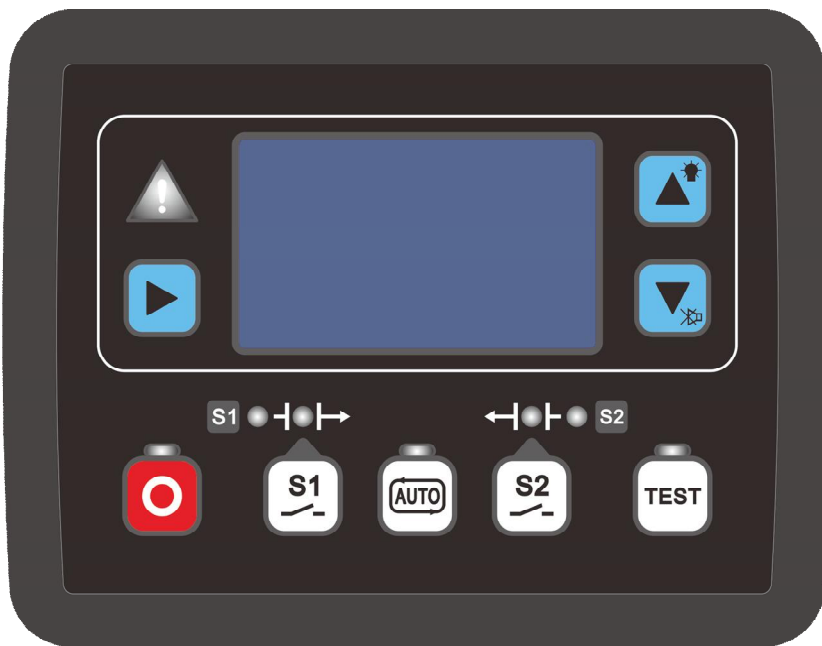
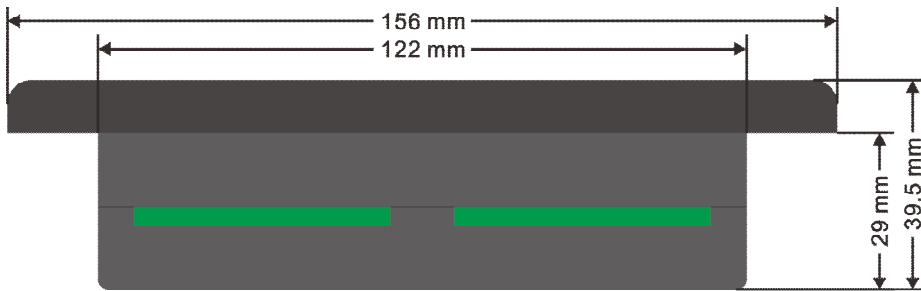

2.2 TU5512 Typical Wiring Diagram:

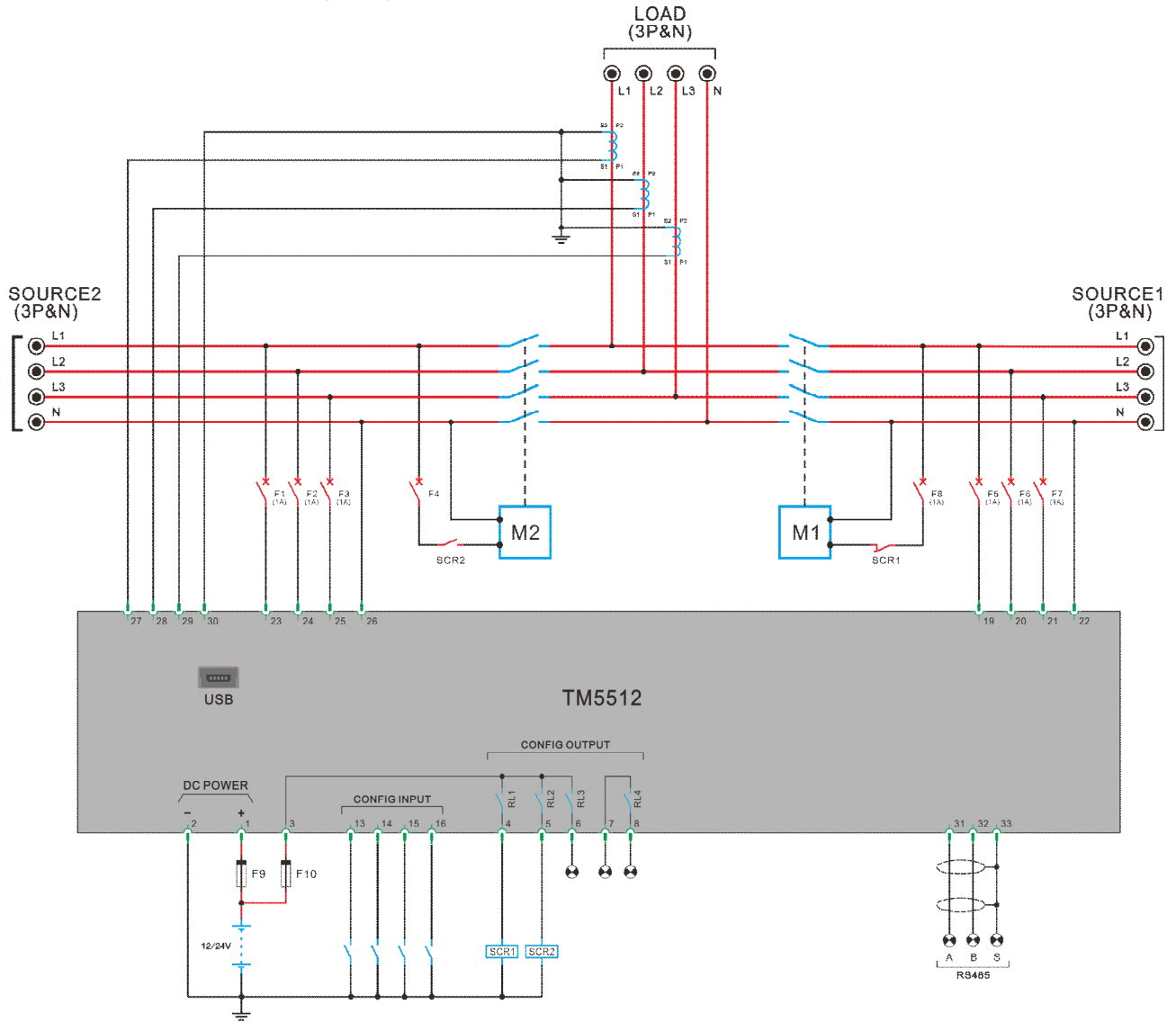

2.3 TU5511 Typical Wiring Diagram:

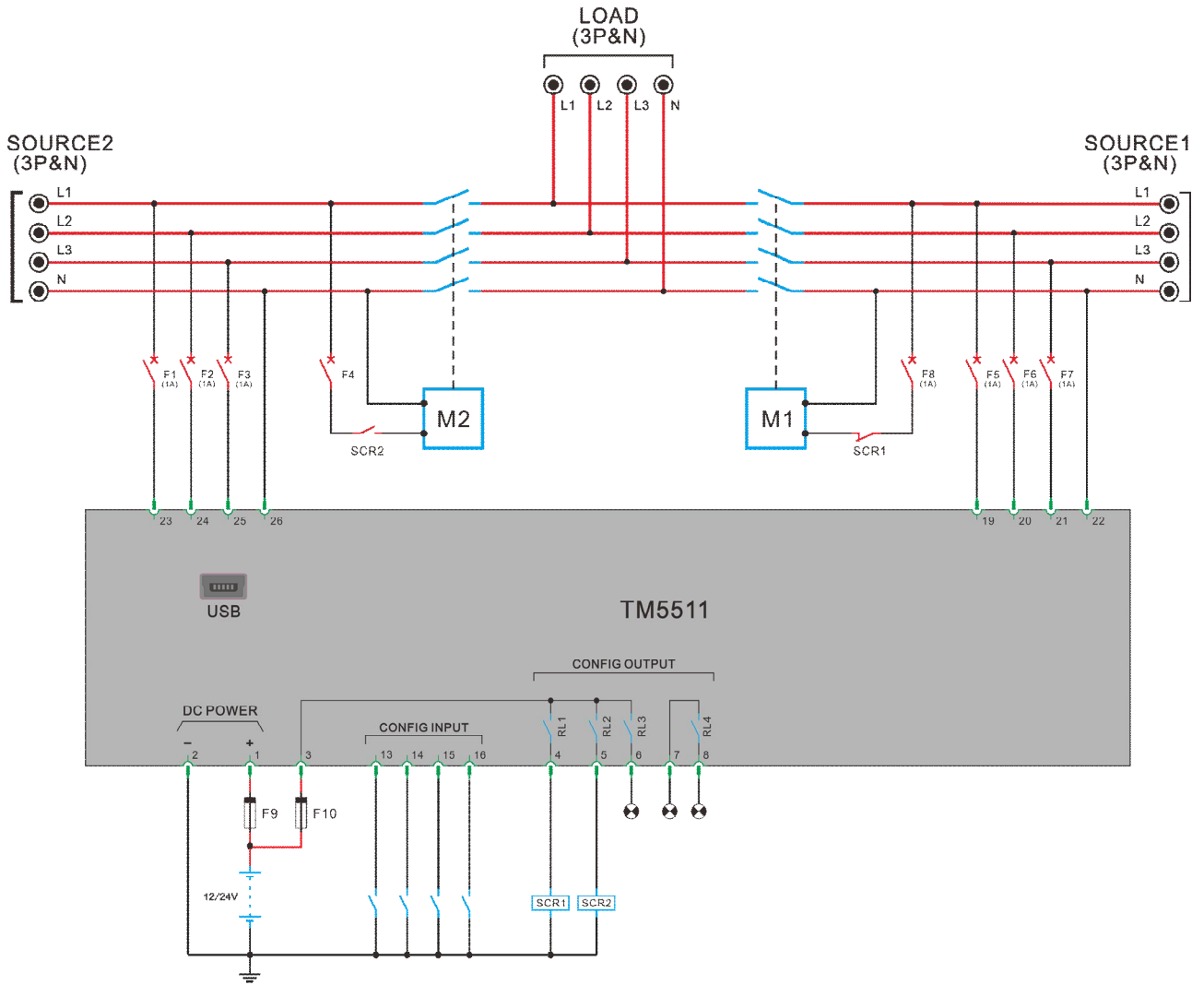







3. Panel Operation





The operation panel consists of 3 sections: LCD display indicating measurement parameters, failure LED, and push buttons for GENset and selection of control modes.

LCD with 132×64 pixels can display multi-line data in the same time. LCD also has a backlight so that the operator can clearly read information day or night. After pressing any button the backlight will automatically turn off after a preset time.

The LCD display and its control push buttons provide a friendly operational interface for the operator to easily control the GENset, read information and parameter setting.

Buttons and LEDs



Function Description	Tag
<p>Scroll Button Scroll menu for parameters display Enter into or exit parameters setting by pressing and holding this button for 2sec</p>	
<p>Lamp Test / “+” Button Pass and hold this button, all lights on the control panel are bright, used to test the indicator whether work. When in parameters setting mode, this key is used to increase the value or move up to select.</p>	
<p>MUTE / “-” Button When failure occurs, alarm buzzer will sound. Pressing mute button will mute the sound. LCD will display mute icon. Press it again will clear the mute function, buzzer will continue to sound. When in parameters setting mode, this key is used to decrease the value or move down to select.</p>	
<p>AUTO Mode Button This button controller operation mode, press this button repeatedly, can choose automatic mode and nonautomatic mode, when the LED indicator light on this button, the controller running in automatic mode. LCD display controller selected mode of operation.</p>	
<p>STOP / RESET Button This key is used to stop the operation mode setting. When the controller runs in the stop mode, the LED on the upper side of the button is light, and the closed relay will be disconnected. When the fault state is locked, press this key to reset the fault.</p>	
<p>Test / Increase Button This key is used to test the operation mode setting. When the controller is running in the test mode, the LED above the button is light. When in parameters setting mode, this key is used to return upwards.</p>	

<p>S1 closing/ opening Button In manual mode, this button is used for closing and opening the load switch. This button is valid when a definable relay is set to "S1 close/open". The indicator light on the button illuminates in two cases: When no D-input is defined as "S1 closed auxiliary contact", the indicator lights illuminates when "S1 closes" action; when the D-input is defined as "S1 closed auxiliary contact", the "S1 closing" action is active and the digital is valid, the light is illuminates. If the "S1 closing" action but the "S1 closing auxiliary contact" digital is invalid, the indication is illuminates.</p>	
<p>S2 closing/ opening Button In manual mode, this button is used for closing and opening the load switch. This button is valid when a definable relay is set to "S2 close/open". The indicator light on the button illuminates in two cases: When no D-input is defined as "S2 closed auxiliary contact", the indicator lights illuminates when "S2 closes" action; when the D-input is defined as "S2 closed auxiliary contact", the "S2 closing" action is active and the digital is valid, the light is illuminates. If the "S2 closing" action but the "S2 closing auxiliary contact" digital is invalid, the indication is illuminates.</p>	
<p>Shutdown Alarm (FAILURE) LED The LED will illuminate when pre-alarm occurs. The LED will illuminate permanently when shutdown alarm occurs.</p>	
<p>S1normal LED When the S1 power supply is normal, that is, the voltage and frequency are within the set high and low limits, the phase sequence is correct and the LED is illuminates.</p>	
<p>S2 normal LED When the S2 power supply is normal, that is, the voltage and frequency are within the set high and low limits, the phase sequence is correct and the LED is illuminates.</p>	

4. Control and Operation Instruction

The controller has five control modes: automatic mode, manual mode, no-load test mode, load test mode, stop mode.

4.1 Operation Mode Setting:

Description	Action
Press the "AUTO" button, the LED is illuminated, the controller is running in "AUTO" mode. Press the "AUTO mode" button again, the LED is off, the controller is running in non-automatic operation mode.	
Press the "Stop Mode" button, the LED on the button is illuminates and the controller is running in stop mode.	
Press the "Test Mode" button, the LED indicator on the button illuminates and the controller runs in the test mode. The test mode with load and no load selection is switched according to the menu.	



NOTE:

Controller keeps the states for the previous mode when changing the operation mode, then implements the control procedure of the next mode according to the present states.



NOTE:

If a defined panel lock switch input will not change the operating mode of the controller.

4.2 MG type (Mains and GEN) control in automatic mode

4.2.1 S1 (Mains) priority control process:

When Mains is normal, Mains supply power:

When the Mains is normal, the Mains normal LED illuminates, the timer of **S1 closing delay** is activated, when it times out, S1 closing relay RL1 close output, transfer switch M1 switch close, M1 Aux, contact close, Mains closing light is illuminated, mains power supply.



NOTE:

When the LED of normal voltage illuminates means the supply power must simultaneously follow:

- I Voltage and frequency are in the range of the setting extreme high/low value.
- I The phase sequence of supply power fits the setting value.
- I Voltage unbalance factor is within the range of setting value.

When the normal voltage indicator flashes, the voltage or frequency exceeds the set high/low limit; when the normal voltage indicator does not light, the supply voltage is less than 10% of the rated voltage.



Caution:

When the equipment is maintained, it is forbidden to judge that there is no power with the light off.

Mains fail to load: If S1 closed relay (RL1) is closed, the timer for **S1 switch closing time** is activated, when it times out, if the controller does not receive the feed back signal from the TS switch M1 Aux. contact close, then Mains fail to load is activated



NOTE:

- I To ensure that the mains closing failure monitoring function is valid, one of the definable input switches must be defined as the S1 closing auxiliary contact.
- I When there is not a configurable D-input defined as S1 closed auxiliary contact, the mains closing indicator light is illuminated, it only indicates the RL1 action output of S1 closing relay.

Power Generation start power supply process:

Controller monitors the following conditions:

- I The mains failure, that is, the mains voltage or frequency exceeds the set limit, and is confirmed by the S1 fault time, the closing relay RL1 disconnects output. If one of the configurable input switches is defined as “remote signal”, the input switch signal must be valid at the same time.
- I Mains closing failed

When any of the above situations occurs, the controller executes the following procedure: S1 closing relay RL1 is disconnected, G2 start delay timer starts, time is up, power Generation remote relay RL4 closes output, GENERator running; when GENERating voltage and frequency is within the set high and low extremum range. The duration is until the end of the S2 settling time. The GEN normal voltage light is illuminated. The S2 closing delay timer starts. The time is up and the S2 closing relay RL2 closes the output, M2 switch is closed, the M2 auxiliary contact is closed, the GENERator closing

indicator is illuminated, and the GENERator is powered.

**NOTE:**

- I To be effective for the closing failure monitoring function, one of the definable input switches must be defined as the S2 closing auxiliary contact.
- I When there is not a configurable input switch defined as S2 closed auxiliary contact, the power Generation closing indicator light illuminated, only indicates the S2 closing relay RL2 action output.

Mains is restored, the mains supply and GENERator shutdown process: When mains is restored to normal, and after S1 settling time delay confirmation, Mains normal light illuminated, S1 closing delay timer is started, time is up, S2 closing relay RL2 disconnect, S1 closing relay RL1 closed output, transition switch M1 switch is closed, M1 auxiliary contacts are closed, Mains closing indicator illuminate, Mains supply.

After the mains supply is normal, G2 cooling time timer is started, time is up, GEN remote start signal relay RL4 disconnect, the GEN shutdown into standby mode.

**NOTE:**

In closing failure occurs, the controller will automatically become auto change but doesn't auto recovery, LCD display closing failed, until troubleshooting and fault reset.

4.2.2 S2 (power) priority control process:

GEN running, power supply: by the end of G2 delay start timer, GEN remote start signal relay of controller RL4 closing output, the GENERator running, when the power voltage and frequency within the range of the high and low extremes set, the duration of time until the end of S2 stable timing, the power Generation voltage is normal, S2 closing delay timer is started, time is up, S2 closing relay RL2 closure output, change-over switch M2 switch is closed, M2 auxiliary contacts are closed, Generation closing indicator illuminates, GEN power.

Voltage GEN failure: when the remote start signal relay RL4 closed output, G2 setup time start timer, time is up, the GEN voltage is not normal; or in the GEN voltage is normal or the GEN supply, the controller detects GEN voltage or frequency extreme value exceeds the set level, S2 fault time timer starts, time is up, the voltage or frequency value has not yet returned to normal levels, namely GEN voltage failure.

GENERator failure: will a configurable switch input is defined as the # 2 GEN failure, when this switch is valid, that is, # 2 GEN failure.

GCB failure: as S2 closing relay RL2 closure output, S2 switch closing time timer is started, time is up, the controller does not detect M2 auxiliary contacts are closed, that is GCB failure

**NOTE:**

- I To GCB failure monitoring function effectively, It must be define a configurable input switch S2 is closed auxiliary contact.
- I When no one configurable input switch is defined as S2 is closed auxiliary contacts, GCB indicator illuminate, only show that S2 is closing relay RL2 closed.

Mains process: when GEN voltage fault, or GENERator failure, or GCB failure, S2 closing relay RL2 disconnect, GEN remote start signal relay RL4 disconnect. So when the mains is normal, that is the mains voltage and frequency are within the set high and low limits, and the mains normal light illuminated. the S1 closing delay timer is started, time is up, S1 closing relay RL1 is closed output, the change-over switch M1 switch is closed, M1 auxiliary contacts are closed, Mains indicator illuminate, Mains supply

GEN recovery, GEN supply process: When GEN troubleshooting and reset, GENERator start and running, after GEN voltage is normal, power voltage indicator illuminate, S2 closing delay timer is started, time is up, S1 closing relay RL1 disconnect, S2 closing relay RL2 closure output, change-over switch M2 switch is close, M2 auxiliary contacts are closed, GEN closing indicator illuminate, GEN supply

**NOTE:**

As long as the power supply voltage is normal, the corresponding power supply voltage indicator illuminated.

4.3 MM type (mains and mains) control process

4.3.1 S1 (1 # mains) priority control process:

1# mains is normal, 1# Mains supply: When 1# mains is normal, 1# Mains normal indicator illuminated, S1 closing delay timer is started, time is up, S1 closing relay RL1 closed output, the change-over switch M1 switch is closed, M1 auxiliary contacts are closed, 1# Mains closing indicator illuminate, 1# Mains supply



WARNING

WARNING:

When the voltage is normal, the power supply must also accord with:

- I voltage and frequency in the high and low extreme of the range setting;
- I Power supply phase sequence in line with the set value;
- I Voltage imbalance within the set value range.

When the normal voltage indicator flashes, the voltage or frequency exceeds the set high limit; when the normal voltage indicator does not illuminated, the supply voltage is less than 10% of the rated voltage.

1# MCB failure: If S1 closing relay RL1 close output, S1 switch closing time timer is started, time is up the controller does not detect M1 auxiliary switch contacts are closed, then 1# MCB failure.

2# mains is normal, 2# mains supply:

When 1# mains voltage failure, and confirmed by S1 downtime, or 1# MCB failure, at this time 2# mains is normal, then 2# mains voltage and frequency within the range of the high and low extremes set, 2# Mains normal indicator illuminated and the controller to perform the following procedures; S1 closing relay RL1 disconnect, S2 closing delay timer is started, time is up, S2 closing relay RL2 closure output, change-over switch M2 switch is closed, M2 auxiliary contacts are closed, 2# Mains closing indicator illuminated, 2# Mains supply

1# mains is restored, 1# Mains supply: When 1# mains voltage returns to normal, and confirmed by S1 stable time, 1# Mains normal indicator illuminated, S1 closing delay timer is started, time is up, S2 closing relay RL2 disconnect, S1 closing relay RL1 close output, change-over switch M1 switch is closed, M1 auxiliary contacts are closed, 1# Mains closing indicator illuminated, 1# mains supply.

4.3.2 S2 (2# mains) priority control process:

2# mains is normal, 2# mains supply:

When 2 # mains is normal, 2# Mains normal indicator illuminated, S2 closing delay timer is started, time is up, S2 closing relay RL2 closure output, schange-over switch M2 switch is closed, M2 auxiliary contacts are closed, 2# Mains closing indicator illuminated, 2# mains supply.

2# MCB failure: If S2 closing relay RL2 close output, S2 switch closing timer is started, time is up, the controller does not detect M2 auxiliary contacts are closed, then 2# MCB failure.

1# mains is normal, 1# Mains supply: When 2# mains voltage failure and confirmed by S2 shutdown, or 2# MCB failure, at this time 1# mains is normal, that 1# mains voltage and frequency within the range of the high and low extremes set, 1# Mains normal indicator illuminated, the controller perform the following procedures: S2 closing relay RL2 disconnect, S1 closing delay timer is started, time is up, S1 closing relay RL1 close output, change-over switch M1 switch is closed, M1 auxiliary contacts are closed, 1# Mains closing indicator illuminated, 1# Mains supply.

2# mains is restored, 2# mains supply: When 2# mains voltage returns to normal, and confirmed by S2 stable time, 2# Mains normal indicator illuminated, S2 closing delay timer is started, time is up, S1 closing relay RL1 disconnect, S2 closing relay RL2 closure output, change-over switch M2 switch is closed, M2 auxiliary contacts are closed, 2# Mains closing indicator illuminated, 2# mains supply.

**NOTE:**

Closing failure occurs, the controller will automatically change but doesn't automatic recovery, LCD display closing failed, until troubleshooting.

4.4 GG-type (power Generation and power Generation) control process

4.4.1 S1 (1# GEN) priority control process:

1# GEN starting processes: automatic mode, G1 start delay timer is started, time is up, 1# GEN remote start signal relay RL3 closure output, 1# GEN start and running, when voltage and frequency within the range of the high and low extremes set, 1# GEN normal indicator illuminated, S1 closing delay timer is started, time is up, S1 closing relay RL1 closed output, change-over switch M1 switch is closed, M1 auxiliary contacts are closed, 1# GEN closing indicator illuminated, GEN supply.



NOTE:

If one of configurable switch input is defined as "remote start", this switch must be valid, then GEN remote start signal relay will be closed output.



WARNING

WARNING:

When the voltage is normal, the power supply must also accord with:

- I voltage and frequency in the high and low extreme of the range setting;
- I Power supply phase sequence in line with the set value;
- I Voltage imbalance within the set value range。

When the normal voltage indicator flashes, the voltage or frequency exceeds the set high limit; when the normal voltage indicator does not illuminated, the supply voltage is less than 10% of the rated voltage.

1# GCB failure: if S1 closing relay RL1 closure output, S1 switch closing time timer is started, time is up, the controller does not detect the M1 auxiliary contacts are closed, that is 1# GCB failure.

1# GEN voltage failure: When 1# GEN remote start signal relay RL3 closure output, G1 start time timer, time is up, the GEN voltage is not normal; or the GEN voltage is normal or the GEN supply, the controller detects power voltage or frequency within the range of extreme high and low settings, S1 down time starts timer, time is up, the voltage or frequency value has not yet returned to normal levels, then 1# GEN voltage failure.

1# GEN failure: one of configurable switch input is defined as 1# GENERator failure, when this switch is valid, that is 1# GENERator failure.

2# GEN start process: When 1# GEN voltage fault and confirmation by S1 fault time delay, or 1# GCB failure, the controller performs the following procedures: S1 closing relay RL1 disconnect, 1# GEN remote start signal relay RL3 disconnect, G2 start delay timer is started, time is up, 2# GEN remote start signal relay RL4 closure output, 2# GENERator start and running; 2# GEN voltage or frequency within the range of extreme high and low settings, 2# GEN normal indicator illuminated, S2 closing delay timer is started, time is up, S2 closing relay RL2 closure output, change-over switch M2 switch is closed, M2 auxiliary contacts are closed, 2# GEN closing indicator illuminated, 2# GEN supply.

1# GEN restored, 1# GEN supply process: When 1# troubleshooting and reset, 1# GENERator start and running; when 1# GEN voltage or frequency within the range of extreme high and low settings, S1 closing delay timer start time, time is up, S2 closing relay RL2 disconnect, S1 closing relay RL1

closed output, change-over switch M1 switch is closed, M1 auxiliary contacts are closed, 1# GEN closing indicator illuminated, 1# GEN supply.

After 1# GEN supply is normal, G2 cooling time timer is started, time is up, 2# GEN remote start signal relay RL4 disconnect, 2# GENERator shutdown and into standby state.

**NOTE:**

Closing failure occurs, the controller will automatically change but doesn't automatic recovery, LCD display closing failed, until troubleshooting.

4.4.2 S2 (2# GEN) priority control process:

2# GEN supply process: G2 start delay timer is started, time is up, 2# GEN remote start signal relay RL4 closure output, 2# GENERator start and running; when the voltage or frequency within the rang of extreme high and low settings, 2# GEN normal indicator illuminated, S2 closing delay timer is started, time is up, S2 close relay RL2 closure output, change-over switch M2 switch is closed, M2 auxiliary contacts are closed, 2# GEN closing indicator illuminated, 2# GEN supply.

**NOTE:**

If one of configurable switch input is defined as "remote start", this switch must be valid, then GEN remote start signal relay will be closed output

**WARNING:**

When the voltage is normal, the power supply must also accord with:

- I voltage and frequency in the high and low extreme of the range setting;
- I Power supply phase sequence in line with the set value;
- I Voltage imbalance within the set value range.

When the normal voltage indicator flashes, the voltage or frequency exceeds the set high limit; when the normal voltage indicator does not illuminated, the supply voltage is less than 10% of the rated voltage.

2# GEN failure: if S2 closing relay RL2 closure output , S2 switch closing time timer is started, time is up, the controller does not detect M2 auxiliary contacts are closed, that is 2# GEN failure.

2# GEN voltage failure: When the 2# GEN remote start signal relay RL4 closure output, G2 setup time start, time is up, the GENERator voltage is not normal; or the GEN voltage is normal or the GEN supply , the controller detects power voltage or frequency exceeds the extreme high and low settings, S2 down time starts, time is up, the voltage or frequency value has not yet returned to normal levels, namely 2# GEN voltage failure.

2# GEN failure: one of configurable switch input is defined as 2# GENERator failure, when this switch is valid, that is 2# GENERator failure.

1# GEN supply process: When 2# GEN voltage fault and confirmation by S2 fault time delay; or 2# GCB failure, the controller performs the following procedures: S2 closing relay RL2 disconnect , 2# GEN remote start signal relay RL4 disconnect, G1 start delay timer is started, time is up, 1# GEN

remote start signal relay RL3 closure output, 1# GENERator start and running, when 1# GEN voltage or frequency within the rang of extreme high and low settings, 1# GEN normal indicator illuminated, S1 closing delay timer is started, time is up, S1 closing relay RL1 closed output, change-over switch M1 switch is closed, M1 auxiliary contacts are closed, 1# GEN closing indicator illuminated, 1# GEN supply.

2# GEN restored, 2# GEN supply process: When 2# troubleshooting and reset, 2# GENERator start and running; when 2# GEN voltage or frequency within the rang of extreme high and low settings, 2# GEN normal indicator illuminated, S2 closing delay timer start time, time is up, S1 closing relay RL1 disconnect, S2 closing relay RL2 closed output, change-over switch M2 switch is closed, M2 auxiliary contacts are closed, 2# GEN closing indicator illuminated, 2# GEN supply. .

After 2# GEN supply is normal, G1 cooling time timer is started, time is up, 1# GEN remote start signal relay RL3 disconnect, 1# GENERator shutdown and into standby state.

5. Measure and display data

S1 V_{Ph-N} L1-N L2-N L3-N

S1 V_{Ph-Ph} L1-L2 L2-L3 L3-L1

S1 frequency (L1)

S2 V_{Ph-N} L1-N L2-N L3-N

S2 V_{Ph-Ph} L1- L2 L2- L3 L3- L1

S2 frequency (L2)

Load 3 phase current I1 I2 I3 (Only TM5512 has)

Load 3 phase apparent power AL1 AL2 AL3 ΣA

Load 3 phase active power and total active power PL1 PL2 PL3 ΣP

Load 3 phase reactive power and total reactive power QL1 QL2 QL3 ΣQ

Load 3 phase power factor PFL1 PFL2 PFL3 PF(AV)

DC power supply (battery) voltage Vdc

6. Parameter settings:**6.1 SYSTEM**

NO.	Items	Setting Range	Preset
1.1	Language		
1.2	Password	0000 to 9999	
1.3	Comm. address	1 to 247	1
1.4	CT Ratio	5:5 to 30000:5	1000:5
1.5	VT Ratio	1.0:1 to 100.0:1	1.0:1
1.6	Rated voltage	45 to 30000VAC	230
1.7	Rated current	1 to 30000A	1000
1.8	Voltage type	1 to 5	1
1.9	Application mode	1 to 3	MG
1.10	Source priority	1/2	1
1.11	Priority hours	0.1 to 12.0 hour / Not used	Not used
1.12	Prohibit return	0/1/2	0
1.13	S1 CB logic	0 N.O/1 N.C	0
1.14	CB close pulse	1 to 60s / 0 Continuous	0
1.15	Startup mode	0 to 2	0
1.16	Display contrast	1 to 9%	5
1.17	Auto scroll time	1 to 60s / Not used	Not used
1.18	Horn reset time	1 to 999s / Not used	Not used
1.19	Default settings		
1.20	Firmware Update		

Menu descriptions:**Language**

- I Used to select the Language which is displayed on the LCD.

Password

- I There are 3 levels of password (CL0/CL1/CL2) for different users.
- I CL0 for the operator, who can read parameters, start and stop controller. The default setting is no password.
- I CL1 for the technician, who has the authority of CL0 and can modify all parameters, the default setting is "1111".
- I CL2 for factory, who have the authority of CL1 and Firmware update, the default setting as "2222".
- I All passwords are automatically inactive 60 seconds after exiting menu.

Comm. address

- I Used to configure ID address for MODBUS.
- I Each controller on the same MODBUS has a unique communication address.

CT Ratio

- I Used to configure the primary and secondary ratios of the load CT, and the secondary current is fixed at 5A.
- I Used to load measurement: KVA, KW, KVAR, PF.
- I Used to warning Failure: Overcurrent, etc.

VT Ratio

- I Measure the voltage value of the power voltage transformer input.
- I Used to voltage detection of the power supply.
- I Used to load measurement: KVA, KW, KVAR, PF.
- I Used to warning Failure: High/Low Voltage.

Rated ph-voltage

- I Used to define the power rated voltage.
- I As a reference value for high / low voltage.

Rated current

- I Used to define the GENERator rated current.
- I As a reference value for overcurrent limit.

Voltage type

I There are 5 voltage types: “Y” 3P4W, “ Δ ” 3P4W, 3P3W, 2P3W, 1P2W.

I “Y” 3P4W (Star three-phase four-wire)

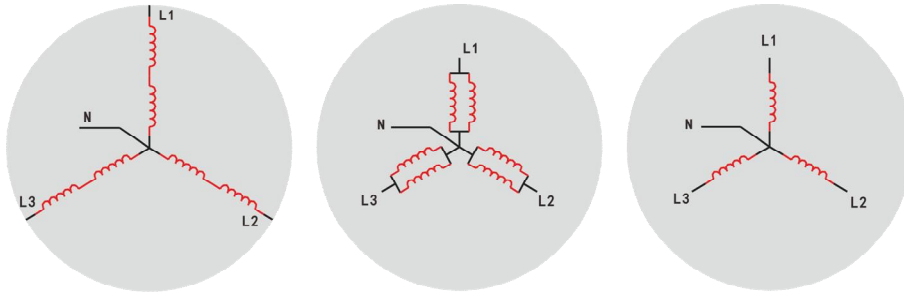

I “ Δ ” 3P4W (Angle three-phase four-wire)

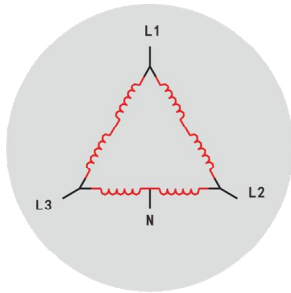

I 3P3W (Three-phase three-wire)

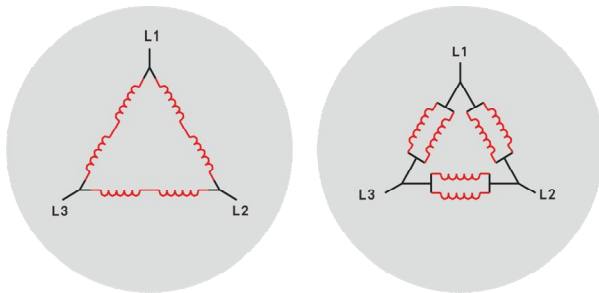

I 2P3W (Two-phase three-wire)

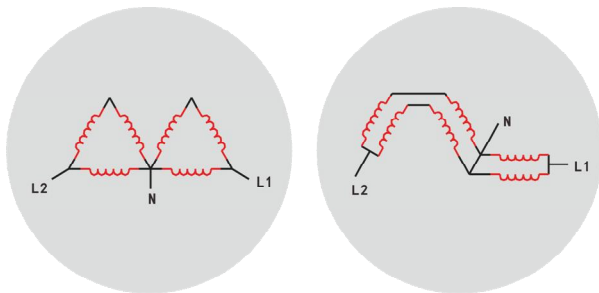

I 1P2W (single phase two-wire)

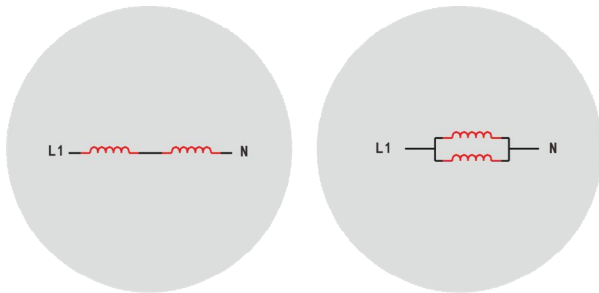

I When the parameter is set to " not use", the controller does not measure, not show the Generation of electrical data.

Application mode

- I This function defines the input power type of the switch.
- I When "1" is MG type, S1 is mains, S2 is power Generation; when "2" is MM type, S1 is 1# mains, S2 is 2# mains; when "3" is GG type, S1 is 1#, S2 is 2# power Generation.
- I After this parameter is changed, restart the controller to take effect.

Source priority

- I This parameter is used to select the priority power.
- I The parameter is set to "1", S1 is the priority power supply, S2 is the standby power supply; parameter is set to "2", S2 is the priority power supply, and S1 is the standby power supply.

Priority hours

- I The duration for setting the power supply as the priority power.
- I When the parameter is set to "not used", the priority level of the two power supplies will not change unless the mode selection key on the control panel of the controller is changed.
- I Effective setting of parameters is valid. The priority timer starts. When the time is over, the power supply is changed from the priority power to the standby power, and the original standby power is changed to the priority power.
- I If for some reason the standby power supply or control mode changes, the priority timer resets.

Prohibit return

- I When the parameter is set to "0", in the automatic operation mode, the power conversion can achieve auto change and auto recovery, that is, after the priority power supply fails, the non-priority power supply is automatically powered, and after the priority power returns to normal, the non-priority power supply is opened, power supply closing power.
- I When the parameter is set to "1", in the automatic operation mode, the power conversion can be realized auto change but doesn't auto recovery, that is, after the priority power supply fails, the non-priority power supply is automatically powered, and after the priority power supply is restored, the non-priority power supply is maintained. , unless the non-priority power failure or human operation, will restore the priority power supply.
- I When the parameter is set to "2", in the automatic operation mode, the power conversion can be auto change but doesn't auto recovery, that is, after the priority power supply fails, the non-priority power supply is automatically powered, even if the priority power supply is returned to normal and the non-preferential power supply is failed. Keep powered by non-priority power.

S1 CB logic

- I Used to selecting S1 normally open or normally closed contact for S1 switch closing relay RL1 to control closing and opening of S1 switch.
- I When the setting value is "normally open", the normally open contact of the closing relay RL1 is selected for the closing control circuit of the S1 switch. The normally open contact of the closing relay RL1 closes when the controller issues the S1 closing command and opens when the controller issues the S1 opening command.

- I When the setting value is "normally closed", the normally closed contact of the closing relay RL1 is selected for the closing control circuit of the S1 switch. The normally closed contact of the closing relay RL1 closes when the controller issues a S1 closing command and opens when the controller issues an S1 opening command.

**NOTE:**

- I In some applications, using S1 as a priority power source, setting the S1 switch logic parameter to "normally closed" is to prevent the controller from malfunctioning due to power loss or burnout. Use normally closed contacts to control the S1 switch closing

**WARNING****WARNING:**

- I Set the S1 switch logic parameter to "normally closed". During the maintenance process, the S1 switch will remain closed due to the controller disconnecting the power supply.

CB close pulse

- I When the parameter is set to "continuous", the closing relay of the controller will continuously close the output unless the controller fails or the opening command.
- I When the parameter is set to "pulse", the controller closes output after the closing command is issued. The timer starts. When the accumulated time reaches the set pulse time, the closing relay open.

Startup mode

- I Used to set the controller's initial control mode when the controller is connected to operating power.
- I When the parameter is set to "0", the controller automatically runs in the manual control mode.
- I When the parameter is set to "1", the controller automatically operates in the automatic control mode.
- I When the parameter is set to "2", the controller's control mode is the same as the previous control mode.

Display contrast

- I Used to adjust the controller LCD display contrast.

Auto scroll time

- I Use to setting the interval of LCD screen display scroll page.
- I When the parameter is set to " not use" , press "▶" manually scroll.
- I Button will start auto scroll page after 30 seconds.

Horn reset time

- I Used to limit the maximum operating time of the alarm. When a warning or failure in the controller, the alarm sounds and the alarm reset time begins. When the time is up, the alarm is cleared. The timer re-times if there is a new warning or failure during the silence or timing of the alarm due to the reset time.
- I When the parameter is set to "not used", the alarm sounds continuously until the warning or fault resets when the controller has a warning or a fault.

Default settings

- I Parameters returned to the factory default.
- I Use CL1 level password to restore the GENeral alarm limit and other parameters for the factory value.
- I Use CL2 level password to restore all parameters to factory values.

Firmware Update

- I Used for the controller is set to online programming mode, after enter the 30 seconds will automatically exit if the upgrade not proceed.
- I Must enter CL2 (Factory) permission password is "2222".
- I Before electrify, press and hold the lamp button can quickly enter the mode.
- I After the upgrade you need to restart the controller.

6.2 MONITORING&CONTROL

NO.	Parameter	Setting range	Preset
2.1	V-monitor type	0 ph-ph/1 ph-n	1
2.2	S1-V under alarm	20 to 200% / Not used	85%
2.3	S1-V under restore	20 to 200%	90%
2.4	S1-HZ under alarm	10.0 to 100.0Hz / Not used	45.0 Hz
2.5	S1-HZ under restore	10.0 to 100.0Hz	48.0 Hz
2.6	S1-V over alarm	20 to 200% / Not used	115%
2.7	S1-V over restore	20 to 200%	110%
2.8	S1-HZ over alarm	10.0 to 100.0Hz / Not used	57.0 Hz
2.9	S1-HZ over restore	10.0 to 100.0Hz	55.0 Hz
2.10	S1 imbalance delay	1 to 20s	5s
2.11	S1 imbalance ALM.	1 to 100% / Not used	4%
2.12	imbalance restore	1 to 100%	2%
2.13	S1 stable time	0 to 600s	5s
2.14	S1 alarm delay	0 to 600s	5s
2.15	S1 close delay	0 to 600s	5s
2.16	Off load time	0 to 600s	0s
2.17	S2-V under alarm	20 to 200% / Not used	85%
2.18	S2-V under restore	20 to 200%	90%
2.19	S2-HZ under alarm	10.0 to 100.0Hz / Not used	45.0 Hz
2.20	S2-HZ under restore	10.0 to 100.0Hz	48.0 Hz
2.21	S2-V over alarm	20 to 200% / Not used	115%
2.22	S2-V over restore	20 to 200%	110%
2.23	S2-HZ over alarm	10.0 to 100.0Hz / Not used	57.0 Hz
2.24	S2-HZ over restore	10.0 to 100.0Hz	55.0 Hz
2.25	S2 imbalance delay	1 to 20s	5s
2.26	S2 imbalance ALM.	1 to 100% / Not used	4%
2.27	imbalance restore	1 to 100%	2%
2.28	S2 stable time	0 to 600s	5s
2.29	S2 alarm delay	0 to 600s	5s
2.30	S2 close delay	0 to 600s	5s
2.31	G1 start delay	0.0 to 600.0 Min	0.1Min
2.32	G1 startup time	0 to 600s	60s
2.33	G1 cooldown time	0 to 600s	5s
2.34	G2 start delay	0.0 to 600.0 Min	0.1Min
2.35	G2 startup time	0 to 600s	60s
2.36	G2 cooldown time	0 to 600s	5s
2.37	overcurrent level	20 to 200% / Not used	100%
2.38	overcurrent delay	1 to 20s	5s
2.39	overcurrent action	0/1/2	0
2.40	Phase rotation	1 CW/2 CCW / Not used	0
2.41	Batt. Undervolt	1.0 to 40.0V / Not used	8.0V
2.42	Batt. Overvolt	1.0 to 40.0V / Not used	35.0V
2.43	S1 CB close time	1 to 999s / Not used	5s
2.44	S1 CB open time	1 to 999s / Not used	Not used
2.45	S2 CB close time	1 to 999s / Not used	5s
2.46	S2 CB open time	1v999s / Not used	Not used
2.47	Test mode	0 unload /1 Load	unload

Menu descriptions:**V-monitor type**

- I Use to select a controller in **ph - ph** voltage or **ph - n** voltage as monitoring object..
- I In different voltage input type, select "**ph - ph**" or "**ph - n**", monitoring voltage is different, specifically in the following table:

Parameter	Ph - ph	Ph - N
Voltage type		
“Y” 3P4W	V_{L1-L2} , V_{L2-L3} , V_{L3-L1}	V_{L1-N} , V_{L2-N} , V_{L3-N}
“△” 3P4W	V_{L1-L2} , V_{L2-L3} , V_{L3-L1}	V_{L1-N} , V_{L2-N} , V_{L3-N}
3P3W	V_{L1-L2} , V_{L2-L3} , V_{L3-L1}	
2P3W	V_{L1-L2}	V_{L1-N} , V_{L2-N}
1P2W		V_{L1-N}

S1/S2-V under alarm

- I Used to define power under voltage alarm value, the under voltage alarm is inactive when parameter configured as “not used”.
- I Expressed by percentage, use “Rated ph-voltage” as the base.
- I Controller will measure phase voltage or line voltage and compared with the set value. When measuring the voltage value is lower than "rated voltage value" * "under voltage fault value", duration greater than "failure time", that is under voltage alarm value

S1/S2-V under restore

- I Used to define the level at which the voltage returns to normal after low voltage supply fault.
- I Expressed by percentage, use “Rated ph-voltage” as the base.
- I Controller will measure phase voltage or line voltage and compared with the set value. When the measured voltage value is higher than the "rated voltage value" * "low voltage restore value" and the duration is greater than the "stable time", the power supply voltage returns to normal.

S1/S2-Hz under alarm

- I Used to define power low frequency fault value, the Hz under alarm is inactive when parameter configured as “not used”
- I Controller will measure power Hz to compared with the set value, When the measured frequency under than the set value and the duration is greater than the "failure time", that is Hz under alarm.

S1/S2-Hz under restore

- I Used to define the power of low frequency failure, the frequency return to normal levels of value.
- I Controller will measure power Hz to compared with the set value, when the measured frequency higher than this setting, the duration greater than "settling time", and the power frequency voltage returns to normal.

S1/S2-V over alarm

- I Used to define the power of the high voltage fault level. When the parameter is set to "no use", the high voltage fault monitoring function is invalid.
- I Expressed by percentage, use “Rated ph-voltage” as the base.
- I Controller will measure phase voltage or line voltage and compared with the set value. When the

measured voltage is higher than "Rated voltage" * "High voltage fault", and the duration time longer than "down time", that is high voltage fault

S1/S2-V over restore

- I Used to define the power of high voltage failure, the voltage returns to normal levels.
- I This number is expressed as a percentage, with "rated voltage value" as a base.
- I The controller measures the phase voltage or line voltage of power and comparison with the set value. When the measured voltage is lower than "Rated voltage" * "High voltage recovery value ", and duration time longer than" settling time ", the power supply voltage returns to normal.

S1/S2-Hz over alarm

- I Used to define the power of high frequency fault level value. When the parameter is set to "not use" high frequency fault monitoring function is invalid.
- I The controller measures the frequency of power and comparative with the set value, when the measured frequency is higher than this setting, duration greater than "down time", that is high frequency failure.

S1/S2-Hz over restore

- I Used to define high frequency failure, the frequency return to normal levels of value.
- I The controller measures the frequency of power and comparative with the set value, when the measured frequency is under than this setting, the duration is greater than "settling time", then power frequency return to normal.

S1/S2 imbalance delay

- I Used to define the duration of the power supply voltage imbalance.

S1/S2 imbalance ALM.

- I Used to define the unbalanced fault level value of the power supply. When the parameter is set to "not used" voltage imbalance fault monitoring function is invalid.
- I Expressed by percentage, use "Rated ph-voltage" as the base.
- I Controller will measure the power phase voltage or line voltage of the power supply and calculate the ratio of the voltage difference between the voltage and the rated voltage. Compared with this set value, when the controller is above this set value, the duration is greater than the "voltage imbalance delay". " is the voltage imbalance error.

S1/S2 imbalance restore

- I Used to define the level of power restore after a voltage imbalance has occurred.
- I Controller will measure the power phase voltage or line voltage of the power supply, and calculate the ratio of the voltage difference between the voltage and the rated voltage. Compared with this set value, if the value is lower than this set value, the power supply will return to normal.

S1/S2 stable time

- I Used to define the delay time in normal power.

- I The controller will measure the frequency of power and voltage, as both are within the setting range and duration greater than the setting, the power supply voltage is normal.

S1/S2 alarm delay

- I Used to define the delay time in power failure.
- I The controller will measure the frequency of power and voltage, as both over any set range and duration greater than the setting value, then power failure.

S1/S2 close delay

- I Used to define the delay time after the normal power supply to the closing relay closure output.

Off load time

- I To realization of delay a certain time to transform to the S1 side after S1 recovery to S2 opening.

G1 start delay

- I Used to define the time between 1# GEN remote start signal output conform to the closing output conditions to remote start signal closing output.
- I This parameter is valid in application mode GG.

G1 startup time

- I Used to define the max. acceptable time between 1# GEN remote start signal closed output to establishment normal voltage.
- I After 1# GEN remote start signal closed output, start to time.
- I This parameter is valid in application mode GG.

G1 cooldown time

- I Used to define 1# GENERator cooling of the running time.
- I After 1# GENERator unload start time, time is up, 1# GEN remote start signal is disconnected output.
- I This parameter is valid in application mode GG.

G2 start delay

- I Used to define the time which is between 2# GENERator remote start signal conforms the closed outputs conditions and remote start signal close output.
- I This parameter is valid in application mode MG/GG.

G2 startup time

- I Used to define the max. acceptable time between 2# GEN remote start signal closed output to establishment normal voltage.
- I After 2# GEN remote start signal closed output, start to time.
- I This parameter is valid in application mode MG/GG.

G2 cooldown time

- I Used to define 2# GENERator cooling of the running time.
- I After 2# GENERator unload start time, time is up, 1# GEN remote start signal is disconnected output.

- I This parameter is valid in application mode MG/GG.

overcurrent level

- I Used to define the limit level of the load overcurrent. When the parameter is set to "not used", the over-current protection function is invalid.
- I Expressed by percentage, use "Rated ph-voltage" as the base
- I Controller will measure three-phase current and compared with the set value. When the current value of any phase of the measured three-phase current is higher than the "rated current" * "overcurrent value" and the duration is greater than the "overcurrent delay", it is an over-current fault.

overcurrent delay

- I Used to define the effective time for confirming an over-current fault.

overcurrent action

- I Used to set the actions that the controller will perform when an overcurrent is acknowledged.
- I There are three parameters that can be set: 0 warning, 1 electrical trip, 2 control.
- I When the parameter is set to "0", if over-current fault occurs, the controller fault indicator illuminated, the alarm buzzer sounds, the relay has been defined as "overcurrent" and the LCD screen displays: "Warning: Over current".
- I When the parameter is set to "1", if overcurrent fault occurs, the controller fault indicator illuminated, the alarm buzzer sounds, the closing relay of the power supply is disconnected, the corresponding generator remote opening relay is disconnected, and the generator stops. , LCD screen shows: "Fault: Over current." Fault status is locked until the fault reset button is pressed.
- I When the parameter is set to "2", if overcurrent fault occurs, except for the relay that has been defined as "overcurrent" to close the output, other controls are not affected.

Phase rotation

- I Ensure during installation, transform switch of two power input phase sequence must be the same, if not, due to the phase sequence does not match, it may cause the control device is not working properly, or even damage.
- I When the parameter is set to "no use", the detection function is invalid.
- I Voltage phase sequence have clockwise and counterclockwise directions different part, clockwise as "L1-L2-L3", with "CW" representation; and counterclockwise as "L1-L3-L2", to "CCW" representation. The controller detects the phase sequence of measurement voltage , if the controller is set to phase sequence clockwise but the measured result is counterclockwise , or the controller is set to counterclockwise but the measured result is clockwise, alarm buzzer. Phase-sequence fault of power can not closing power supply.

Batt. Undervolt

- I Used to define the low level value for detecting the DC supply voltage.
- I When the measured DC power supply voltage is lower than this set value, the controller fault indicator flashes, the alarm buzzer sounds, the relay has been defined as "battery low voltage" closed output, LCD display: "Warning: low battery voltage".

Batt. Overvolt

- I Used to define the high level of detection of DC supply voltage.
- I When the measured DC supply voltage is higher than this set value, the controller fault indicator flashes, the alarm buzzer sounds, the relay has been defined as "battery high voltage" closed output, LCD display: "Warning: high battery voltage".

S1 CB close time

- I The controller which can monitor S1 switch of transform switch to the success of the closing, when the parameter is set to "Not used", this function is disabled.
- I When the function is enabled, after S1 closing relay close output, S1 switch closing time begins, time is up, M1 switch has not been closing, S1 switch closing fault trigger. When S1 closing fault occurs, closing indicator light flashes, alarm buzzer, has been defined as "S1 closing failed" relay close output, LCD screen shows: "Failure: S1 close failed", fault status locked until you press the Reset key

S1 CB open time

- I The controller which can monitor S1 switch of transform switch to the success of the opening, when the parameter is set to " Not used ", this function is disabled.
- I When the function is enabled, after S1 closing relay disconnect output, S1 switch opening time begins, time is up, M1 switch has not been opening, S1 switch opening fault trigger. When S1 opening fault occurs, closing indicator light flashes, alarm buzzer, has been defined as "S1 opening failed" relay close output, LCD screen shows: "Fault: S1 open failed", fault status locked until you press the Reset key.

S2 CB close time

- I The controller which can monitor S2 switch of transform switch to the success of the closing, when the parameter is set to " Not used ", this function is disabled.
- I When the function is enabled, after S2 closing relay close output, S2 switch closing time begins, time is up, M2 switch has not been closing, S2 switch closing fault trigger. When S2 closing fault occurs, closing indicator light flashes, alarm buzzer, has been defined as "S2 closing failed" relay close output, LCD screen shows: "Failure: S2 close failed", fault status locked until you press the Reset key.

S2 CB open time

- I The controller which can monitor S2 switch of transform switch to the success of the opening, when the parameter is set to " Not used ", this function is disabled.
- I When the function is enabled, after S2 closing relay disconnect output, S2 switch opening time begins, time is up, M2 switch has not been opening, S2 switch opening fault trigger. When S2 opening fault occurs, closing indicator light flashes, alarm buzzer, has been defined as "S2 opening failed" relay close output, LCD screen shows: "Fault: S2 open failed", fault status locked until you press the Reset key.

6.3 CONF. INPUT/OUTPUT

NO.	Items	Value Range	Preset
3.1	D-Input 1 function	1 to 30 / Not used	Not used
3.2	D-Input 1 logic	0 closed /1 open	0
3.3	D-Input 1 delay	0 to 999s	0
3.4	D-Input 2 function	1 to 30 / Not used	Not used
3.5	D-Input 2 logic	0 closed /1 open	0
3.6	D-Input 2 delay	0 to 999s	0
3.7	D-Input 3 function	1 to 30 / Not used	Not used
3.8	D-Input 3 logic	0 closed /1 open	0
3.9	D-Input 3 delay	0 to 999s	0
3.10	D-Input 4 function	1 to 30 / Not used	Not used
3.11	D-Input 4 logic	0 closed /1 open	0
3.12	D-Input 4 delay	0 to 999s	0
3.13	Relay 3 function	1 to 80 / Not used	Not used
3.14	Relay 3 logic	0 N.O /1 N.C	0
3.15	Relay 4 function	1 to 80 / Not used	Not used
3.16	Relay 4 logic	0 N.O /1 N.C	0

Menu descriptions:**D-Input * function**

I Used to define the digital input function.

I Configurable D-input function menu as follow:

NO.	Function	Description
0	Not used	
1	Warning	When the signal is valid, the warning indicator flashes, the alarm buzzer sounds, and the LCD screen displays: "Warning: Input digital **"
2	Alarm	When the signal is active, warning light illuminated, the alarm buzzer, all closing relay and the generator remote start relay output disconnect. LCD screen shows: " Alarm:Input digital **".
3	Panel lock	When you select this function digital input signal is active, you can not modify the operating parameters of the operation panel on the controller, cannot select the operating mode. The LCD screen shows: "Panel lock".
4	Inhibit ATS	When you select this function digital input signal is active, the controller disconnect all closing relay output. The LCD screen shows: " Inhibit ATS ". This input is connected to an external switch, for manually operated switch or switch maintenance, prevent transfer switch automatic transfer. Defined as "generator remote start" relay action is not affected by the input.
5	Remote start	When this input is active (priority) generator remote start relay close output, normal operation after power issue closing command. This signal is valid only in the automatic mode of operation.
6	GEN.1 alarm	This input is connected with the shutdown fault signal of the controller, this input is active, it indicates 1# generator downtime, relay RL3 disconnect, alarm buzzer. LCD screen shows: "S1 generator failure."
7	GEN.2 alarm	This input is connected with the shutdown fault signal of the controller, this input is active, it indicates 2# generator downtime, relay RL4 disconnect, warning light illuminated, , alarm buzzer, LCD screen shows: "S2 generator failure."
8	S1 closed aux.	Select this function the D-input port is connected to transfer switch of S1 power side switch of auxiliary contacts, used for monitoring S1 switch closing or opening state.
9	S2 closed aux.	Select this function the D-input port is connected to transfer switch of S2 power side switch of auxiliary contacts, used for monitoring S2 switch closing or opening state.
10	Lamp test	Select this function digital input signal is active, the indicator on the controller operation panel all illuminate. Functional is equivalent the control panel "lamp test" button.
11	Alarm reset	Select this function digital input signal is active, and the controller of the fault locking will be unlocked.
12	EmerGENcy stop	Select this function D-input port external connect a emergency stop switch, when the input is active, the controller immediately disconnect all control output, alarm buzzer. LCD screen shows: "emergency stop."
13	Inhibit S1 to load	Select this function D-input signal is valid, regardless in any case, the S1 closing relay of controller will not closure outputs. LCD screen shows: "Limit S1 power supply".

14	Inhibit S2 to load	Select this function D-input signal is valid, regardless in any case, the S2 closing relay of controller will not closure outputs. The LCD screen shows: "Limits S2 power supply."
15	Prohibit return	Select this function D-input signal is valid, caused by the priority power failure to non-priority power load, when the priority power is restored to normal , will remain non-priority power loads, unless the digital input signal becomes invalid, or manually changed. This function is equivalent to parameter limit is set to "1".
16	Activate AUTO mode	When selecting this digital input signal of function is active, the controller change to auto operation mode, which provides users with a remote button to select auto operation mode. This operating mode selection function is not affected by panel lock.
17	Activate MAN mode	When selecting this digital input signal of function is active, the controller change to manual operation mode, which provides users with a remote button to select manual operation mode. This operating mode selection function is not affected by panel lock.
18	TEST on load	When selecting this digital input signal of function is active, the controller change to test on load operation mode, which provides users with a remote button to select test operation mode. This operating mode selection function is not affected by panel lock
19	TEST off load	When selecting this digital input signal of function is active, the controller change to test off load operation mode, which provides users with a remote button to select test operation mode. This operating mode selection function is not affected by panel lock
20	Activate STOP mode	When selecting this digital input signal of function is active, the controller change to stop operation mode, which provides users with a remote button to select test operation mode. This operating mode selection function is not affected by panel lock
21	lock mode	When selecting this digital input signal of function is active, the controller will not switch to another power supply, but it will open when there is a fault, and will reclose after the fault is recovered.
22	Critical mode	In critical mode, the remote relay output, after the power Generation closes, the fault will not alarm but it will open, and the remote relay will remain closed.
23	Alarm mute	When selecting this digital input signal of function is active, the alarm buzzer sound of the controller will stop and relay output defined as "audio alarm" will be turned off. The function of this input signal is equivalent to the "Silent" key on the controller panel
24	Source priority	When the digital has this code set, whether the input is valid or not is selected as the priority power source regardless of the menu (priority power supply) setting; when the digital input is invalid: S1 is the priority power source, S2 is the standby power source; when the digital input is valid: S2 is the priority power supply, and S1 is the standby power supply;
25-30	Reserve	

D-Input * logic

- I Used to select D-input is effective at the time of normally open or normally closed.
- I Select "0", the digital input closed (low level) effective; select "1", the digital input open effective.

D-Input * delay

- I Used to select delay time value of D-input effective continuous, such as digital delay is effective until terminated become invalid, the delay time is set to zero

Relay * function

- I Used to configurable relay for function selection.
- I Selectable functions in the following table:

NO.	Function	Description
0	Not used	
1	Warning	Select this function, the output relay running when occurrence of one or more of warning, after fault clearance, its stop.
2	Alarm	Select this function, the output relay running when occurrence of one or more of shutdown fault, after fault clearance and press the fault reset, then its stop.
3	Over current	When the load current is higher than the set value of the overcurrent value and the delay is confirmed, its action.
4	AUTO mode	Output relay action, when controller running in the auto operation mode.
5	TEST mode	Output relay action, when controller running in the test operation mode.
6	MAN mode	Output relay action, when controller running in the manual operation mode.
7	STOP mode	Output relay action, when controller running in the Stop operation mode.
8	GEN.1 remote start	Select this function, the output relay is action in the controller issue 1# generator start command. Under normal circumstances, the controller can define relay RL3 or RL4 which is selected object, it can ensure that controllers at the loss work power to the relay normally closed contact to start the generator. This function relay is only valid in the application model GG.
9	GEN.2 remote start	Select this function, the output relay is action in the controller issue 2# generator start command. Under normal circumstances, the controller can define relay RL3 or RL4 which is selected object, it can ensure that controllers at the loss work power to the relay normally closed contact to start the generator. his function relay is only valid in the application model MG or GG .
10	GEN.1 alarm	Select this function, the output relay is action, when one of D-input is defined as 1# generator fault is valid.
11	GEN.2 alarm	Select this function, the output relay is action, when one of D-input is defined as 2# generator fault is valid.
12	S1 fail to close	Output relay action, after the S1 closing failure occurred.
13	S2 fail to close	Output relay action, after the S2 closing failure occurred.
14	S1 fail to open	Output relay action, after the S1 opening failure occurred.
15	S2 fail to open	Output relay action, after the S2 opening failure occurred.

16	Batt. over volt	When the controller detects that the battery voltage is higher than the battery high warning value setting value action.
17	Batt. under volt	When the controller detects that the battery voltage is lower than the battery low warning value setting value action.
18	S1 alarm	Select this function, the output relay is action, in 1 power supply occurred low-voltage, high voltage, low frequency, high frequency, or phase mismatch.
19	S1 over volt	Select the function of the output relays, in 1 power supply voltage is higher than setting values of S1 high voltage fault value, after delay confirmation, it is action, has remained until the voltage is lower than the setting of S1 high voltage recovery value and press the reset button.
20	S1 under volt	Select the function of the output relays, in 1 power supply voltage is lower than setting values of S1 low voltage fault values, after delay confirmation, it is action, has remained until the voltage is higher than the setting of S1 low voltage recovery value and press the reset button.
21	S1 high Hz	Select the function of the output relays, in 1 power supply frequency is higher than setting values of S1 high frequency fault values, after delay confirmation, it is action, has remained until the frequency is lower than the setting of S1 high frequency recovery value and press the reset button.
22	S1 under Hz	Select the function of the output relays, in 1 power supply frequency is lower than setting values of S1 low frequency fault values, after delay confirmation, it is action, has remained until the frequency is higher than the setting of S1 low frequency recovery value and press the reset button.
23	S1 imbalance	Select the function of the output relays, the ratio of the voltage difference between each phase of the power supply 1 and the rated voltage is higher than the set value of the S1 unbalanced fault value. After the delay is confirmed, the operation is continued until it is lower than the setting value of the unbalance recovery value of S1, and press the reset button.
24	S1 Ph. Rot. mismatch	Select this function, the output relay is action, in the 1 power supply phase sequence does not match the fault until the fault is cleared and press the reset button.
25	S2 alarm	Select this function, the output relay is action, in the 2 power supply of low voltage, high voltage, low frequency, high frequency, or phase mismatch.
26	S2 over volt	Select the function of the output relays, in 2 power supply voltage is higher than setting values of S2 high voltage fault value, after delay confirmation, it is action, has remained until the voltage is lower than the setting of S2 high voltage recovery value and press the reset button.
27	S2 under volt	Select the function of the output relays, in 2 power supply voltage is lower than setting values of S2 low voltage fault values, after delay confirmation, it is action, has remained until the voltage is higher than the setting of S2 low voltage recovery value and press the reset button.
28	S2 high Hz	Select the function of the output relays, in 2 power supply frequency is higher than setting values of S2 high frequency fault values, after delay confirmation, it is action, has remained until the frequency is lower than the setting of S2 high frequency recovery value and press the reset button.

29	S2 under Hz	Select the function of the output relays, in 2 power supply frequency is lower than setting values of S2 low frequency fault values, after delay confirmation, it is action, has remained until the frequency is higher than the setting of S2 low frequency recovery value and press the reset button.
30	S2 imbalance	Select the function of the output relays, the ratio of the voltage difference between each phase of the power supply 2 and the rated voltage is higher than the set value of the S2 unbalanced fault value. After the delay is confirmed, the operation is continued until it is lower than the setting value of the unbalance recovery value of S2, and press the reset button.
31	S2 Ph. Rot. mismatch	Select this function, the output relay is action, in the 2 power supply phase sequence does not match the fault until the fault is cleared and press the reset button.
32	Off load	Select this function, the output relay is action, when the controller closing relay RL1 and RL2 are disconnect, and when does not action in any one closed.
33	Load disconnect	Select this function the output relay, it is action in controller S1 or S2 closing delay timer starts work, not action after the corresponding power closing supply. This relay can be used to control when the control transform switch conversion, cutting off part of the non-critical load or all load, in order to reduce the impact of the transform instant impulse current.
34	Scheduled	Select this function, the output relay is action, when the timing operation is valid.
35-43	Reserve	
44	D-Input 1 alarm	The digital input 1 is set to operate when the "warning" or "fault" input is valid.
45	D-Input 2 alarm	The digital input 2 is set to operate when the "warning" or "fault" input is valid.
46	D-Input 3 alarm	The digital input 3 is set to operate when the "warning" or "fault" input is valid.
47	D-Input 4 alarm	The digital input 4 is set to operate when the "warning" or "fault" input is valid.
48-80	Reserve	

Relay * logic

- I Used to select the relay output is normally open or normally closed state.
- I To select "0", the relay in effective implementation is active; choose "1", the relay is invalid in effective implementation.

6.4 SCHEDULED

No.	Parameter	Setting range	Preset
4.1	DATE/ TIME	YY-MM-DD HH:MM:SS	
4.2	Scheduler mode	0 Unload/1 load	Unload
4.3	Start time		HH:MM
4.4	Run duration	1 to 1440 min	5 min
4.5	Monday active	0 N/1 Y	No
4.6	Tuesday active	0 N/1 Y	No
4.7	Wednesday active	0 N/1 Y	No
4.8	Thursday active	0 N/1 Y	No
4.9	Friday active	0 N/1 Y	No
4.10	Saturday active	0 N/1 Y	No
4.11	Sunday active	0 N/1 Y	No

Menu descriptions:

DATE/TIME

- I Used to configure the date / time: YY-MM-DD HH:MM:SS。
- I The date displayed on LCD, the pre-alarm (warning) and alarm events with time stamp.

Scheduler mode

- I Used for the controller in the scheduling model was activated, what kind of the control function to choose;
- I When you select "unload" controller running in test mode, the generator start running, transfer switch does not convert, that is, mains power supply continues, mains continue to supply, generator unload operation; if choose "load" controller running in test mode, the generator start running, the transfer switch is converted, that is power Generation supply power.

Start time

- I Used to configure the start time when controller is active in exercise run scheduler.

Run duration

- I Used to configure the duration when controller is active in exercise run schedule, the scheduler mode will be reset after run duration has expired.

MON active

- I The cycle of exercise run scheduler is one week. This menu is used to configure the exercise run schedule on Monday active or not.

TUE active

- I Used to configure the exercise run schedule on Tuesday active or not.

WED active

- I Used to configure the exercise run schedule on Wednesday active or not.

THU active

- I Used to configure the exercise run schedule on Thursday active or not.

FRI active

I Used to configure the exercise run schedule on Friday active or not.

SAT active

I Used to configure the exercise run schedule on Saturday active or not.

SUN active

I Used to configure the exercise run schedule on Sunday active or not.

**NOTE:**

The scheduling function is only valid in the MG/GG application mode. In the MG application mode, the start and stop of the generator is scheduled. In the GG application mode, the priority unit is scheduled to start and stop.

6.5 CALIBRATION

No.	Parameter	Setting range	Preset
5.1	S1-V1 offset	-9.9% to 9.9%	
5.2	S1-V2 offset	-9.9% to 9.9%	
5.3	S1-V3 offset	-9.9% to 9.9%	
5.4	S2-V1 offset	-9.9% to 9.9%	
5.5	S2-V2 offset	-9.9% to 9.9%	
5.6	S2-V3 offset	-9.9% to 9.9%	
5.7	Current I1 offset	-9.9% to 9.9%	
5.8	Current I2 offset	-9.9% to 9.9%	
5.9	Current I3 offset	-9.9% to 9.9%	
5.10	Batt. V offset	-9.9% to 9.9%	

Menu descriptions:**S1-V1 offset**

- I Used to modify the measured value display of U1 power V1 voltage.
- I Reference to the Rated ph-voltage.

S1-V2 offset

- I Used to modify the measured value display of U1 power V2 voltage.
- I Reference to the Rated ph-voltage.

S1-V3 offset

- I Used to modify the measured value display of U1 power V3 voltage.
- I Reference to the Rated ph-voltage.

S2-V1 offset

- I Used to modify the measured value display of U2 power V1 voltage.
- I Reference to the Rated ph-voltage.

S2-V2 offset

- I Used to modify the measured value display of U2 power V2 voltage.
- I Reference to the Rated ph-voltage.

S2-V3 offset

- I Used to modify the measured value display of U2 power V3 voltage.
- I Reference to the Rated ph-voltage.

Current I1 offset

- I Used to modify the measured value display of current I1.
- I Reference to the Rated current.

Current I2 offset

- I Used to modify the measured value display of current I2.
- I Reference to the Rated current.

Current I3 offset

- I Used to modify the measured value display of current I3.
- I Reference to the Rated current.

Batt. V offset

- I Used to modify the measured value display of battery voltage.

7. Installation Guide

7.1 The cutout dimensional drawing installed on panel as follows:

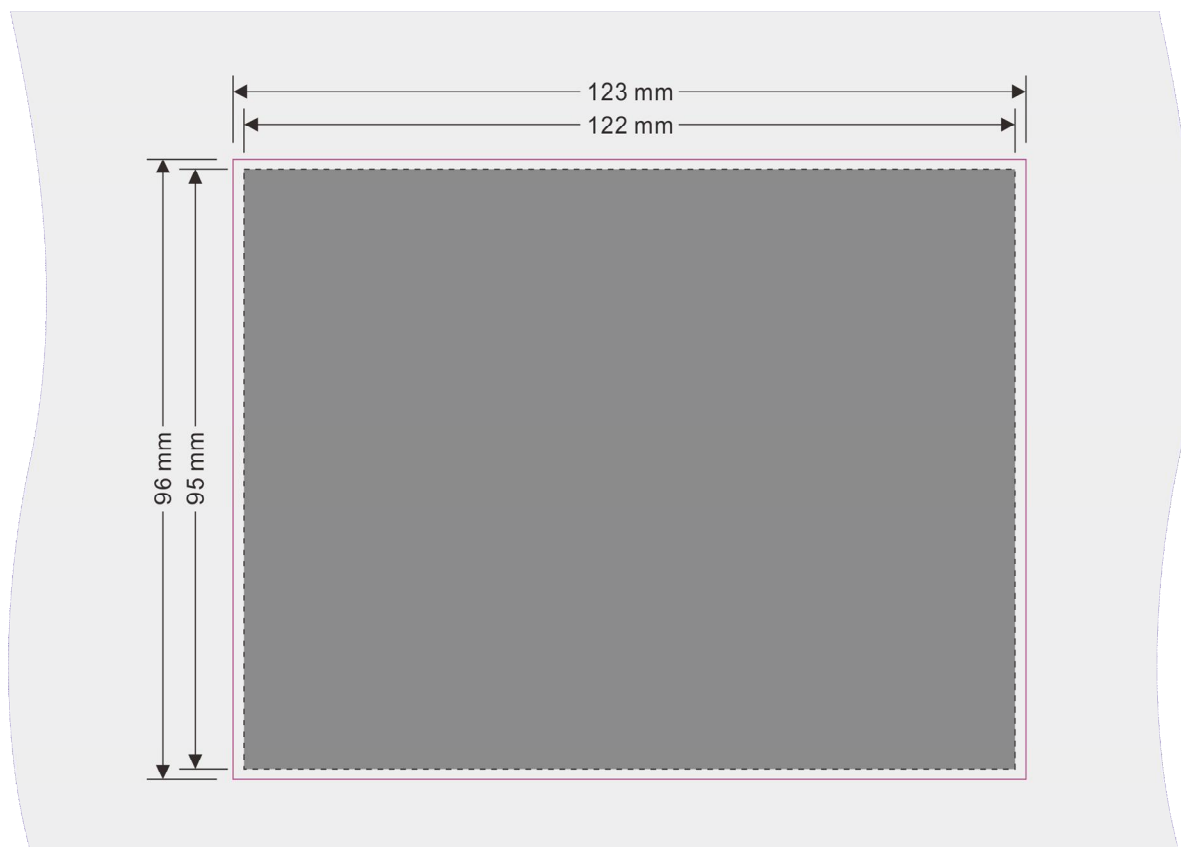

Cutout dimension: 123mm(W) x 96mm (H), Dashed box dimensions for the controller.
The controller is fixed by 2 special fittings.

**NOTE:**

- I The shock-proof equipment must be mounted if the enclosure is mounted on Genset or other heavy vibrant device.
- I In order to ensure the degrees of protection of the mounted controller meet IP55, the cutout dimension on the panel must be correct.

8. LCD displays and Menu System

8.1 LCD displays measuring parameters:

Use a back-light graphic LCD to display data and information. Each page can display multi-row information simultaneously, the above 4 rows display measuring data, the last row displays status information, press “▶” to scroll for viewing next page, it can be configured as auto scroll as well. When alarm occurs, the alarm status is displayed on the LCD immediately.

Frist page



Description

- I Display application mode
- I The average frequency and line voltage of the two power supplies

Second page



Description

- I Display voltage and frequency of S1 power supply

Third page

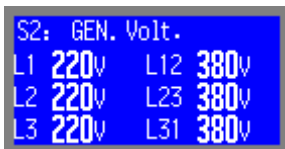

Description

- I Display voltage and frequency of S2 power supply

Four page

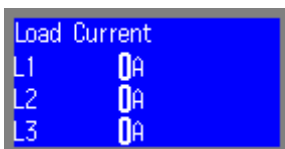

Description

- I Display load current

Five page

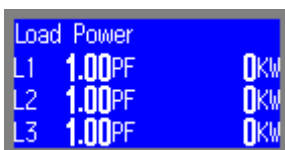

Description

- I This page shows the three-phase active power and power factor for power Generation.

Six page



Description

- | This page shows the three-phase apparent power and reactive power generated.

Seven page



Description

- | Display load power, DC operating supply voltage

Eight page

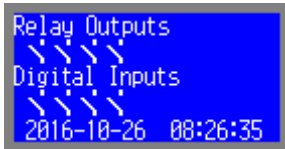

Description

- | Display input discrete and output relay operating status
- | Display date and time

Nine page

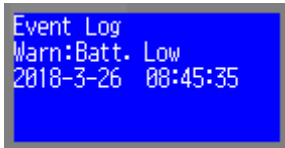

Description

- | This page shows the controller's recent failure



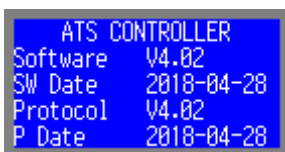







Ten page















Description

- | This page shows the controller version and other information

8.2 Setting running parameter

Parameter settings are modified by increment or decrement, press and hold on any page  button 2sec to enter into setting state, then press  or  to scroll page in the same menu list, press  enter into submenu, need to modify the parameters first enter to menu 1.2 "password" enter the permission password to modify; or select the items to be modified, press  enter to menu to modify mode, press  or  to changes, when prompted for password 0 0 0 , At this time can press  or  enter the password, set the password value to 1111 and then press  confirm entry, modify the parameters. Otherwise re-prompt for a password. After changing the parameters, press and hold  for 2seco quit parameter settings mode.

FOR EXAMPLE: (SETTING CT RATIO AT 500: 5, THEN CT SHOULD BE CONFIGURED AS 500)

Operation	Description
Press and hold  2sec, enter into parameters setting menu, then LCD displays:	[SETTING] 0. QUIT 1. SYSTEM 2. Monitoring 3. SETTING
Press  once, press  6 times again, then press  once, LCD displays:	[CT ratio] 1000: 5
Press  or  prompted enter password, the modify password is:1111; Press  to be modified the bits, press  to enter.	[CT ratio] Password:0000
Press  or  to change parameters, this time modified to 500, LCD then display	[CT ratio] 500: 5
Press  to confirm, LCD then display:	[SYSTEM] 0. QUIT 1. Language 2. Password 3. Comm. Address 4. CT ratio
Press and hold  2sec to quit the settings menu, then LCD displays	Ready

Example: (the parameters of the controller reverts to the factory default values)

Operation	Description
Press and hold  2sec, enter into parameters settings menu, then LCD displays:	[SETTING] 0. QUIT 1. SYSTEM 2. Monitoring 3. SETTING

<p>Press “▶” button and then press “▲” 3 times, then LCD displays:</p>	<p>[SYSTEM] 16. Display 17. Scroll 18. Reset 19. Default settings</p>
<p>Press “▶” button, prompted enter password: 1111, press “▶” button to confirm after entering password.</p>	<p>[Default settings] Password:0000</p>
<p>Press “▶” to default settings, press and hold “▶” 2sec will quit parameter settings menu.</p>	<p>[SYSTEM] DONE</p>

Example: (CONFIGURE CONTROLLER AS ONLINE PROGRAM MODE)

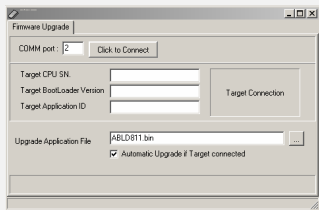
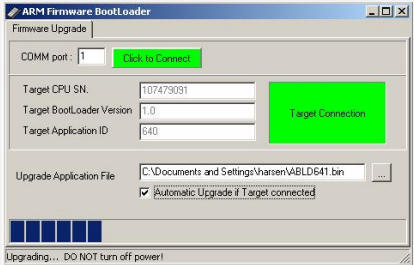
<p>Open the programming software "ABLDs.exe" on your computer, such as the right to import the upgrade process, the controller connected to the computer via cable Minu USB, the computer will recognize the serial port software to fill "COMM port", but do not open the serial port, as following methods to enter programming mode.</p>	
<p>Press and hold “▶” 2sec, enter into parameters settings menu, then LCD displays:</p>	<p>[SETTING] 0. QUIT 1. SYSTEM 2. Monitoring 3. SETTING</p>
<p>Press “▶” button, then press “▲” 2 times, LCD displays:</p>	<p>[SYSTEM] 17. Scroll 18. Reset 19. Default settings 20. Update</p>
<p>Press “▶” button, prompted enter password: 2222, then press “▶” to confirm</p>	<p>[Default settings] Password:0000</p>
<p>Press “▶” to confirm enter the programming mode, then the controller LCD disappears, later click computer software "ABLDs.exe" serial port “Click to Connect”, then it will automatically upgrade.</p> <p>In this mode it must ensure that the normal power supply, communication line connection will not be interrupted, restart the controller to work after a successful upgrade program.</p> <p>If the operation failure, you can disconnect the power and try again.</p>	

9. Technical Specification

9.1 AC voltage measurement

Measurement type	True RMS
Phase to Neutral	15 to 345VAC
Phase to Phase	25 to 500VAC
Max power consumption per path	<0.37W
Accuracy	1%
Display	0 to 500KV

9.2 AC voltage frequency measurement

Measuring frequency	3 to 100Hz (voltage≥15VAC)
Accuracy	0.1%
Display	0 to 100Hz

9.3 Current measurement (isolated)

Measurement type	True RMS
Measuring current	5A
Accuracy	1%
Display	0 to 30000A
Max power consumption per path	<0.01W

9.4 Power supply

Range	12V/24V (8-35V) continuous
Max. operating current	@12V 150mA, @24V 75mA
Accuracy	1%
Display	0 to 40V

9.5 D-input

Number	4
Max. contact resistance	5KΩ
Max. contact resistance per path	1mA

9.6 Relay outputs

Quantity	4
Relay	3A/30Vdc

9.7 Ambient parameters

Operating temperature range Standards	-20 to 70°C IEC60068-2-1 and IEC60068-2-2
Storage temperature range Standards	-30 to 80°C IEC60068-2-1 and IEC60068-2-2
Humidity Standards	40°C, 93%RH, 96 hours IEC60068-2-30
Electromagnetic compatibility Standards	EN 61000-6-4 and EN 61000-6-2
Vibration Standards	EN 60068-2-6
Shock Standards	EN 60068-2-27
Electrical safety Standards	EN 60950-1
Degrees of protection Standards	IP55 (front) IP20 (back) BS EN 60529